



PROCESS EQUIPMENT
FOR MUNICIPAL & INDUSTRIAL
WATER & WASTE WATER TREATMENT PLANTS



ISO 9001:2015 Certified



A Subsidiary of
JASH ENGINEERING LTD.





SHIV PAD
ENGINEERS PVT. LTD.

A Subsidiary of
JASH ENGINEERING LTD.



Contents



About Shivpad	4
Screens	8
Detritors	11
Clariflocculators	13
Surface Aerators	16
Clarifiers	18
Thickeners	21
Trickling Filter	22
Digester Mixer	23
Floating Decanter	24
Lime Classifier	25
Other Products from JASH	26

Reliable products for a Sustainable future

A Subsidiary of

JASH ENGINEERING LTD.



Shivpad Engineers Pvt. Ltd., Chennai is an ISO 9001-2008 certified company established in the year 1990 to manufacture Process Equipment for Water Treatment, Waste Water Treatment and Sewage Treatment Plants and pumping stations.

Shivpad offers diversified Process Equipment comprising of both Fine & Coarse Screens, Detritors, Clarifiers, Thickeners, Digester Mixers, Trickling Filters and Rectangular Clarifiers, both fixed & floating Surface Aerators, Decanters and Lime Classifiers. In addition to these products Shivpad can offer Chemical Process Industry equipment related to solid – liquid separation viz., Milk of Lime preparation plant Equipment, Multi-deck Clarifiers, Rake & Screw Classifiers and various other tailor-made equipment to suit each process application and clients' needs.

Over the period of two decades, Shivpad has successfully installed Process Equipment to more than 200 major projects in India. During the last 10 years Shivpad has also supplied equipments to projects in Singapore, Malaysia, Qatar, Sri Lanka, Muscat, Brunei, Vietnam, Thailand, Indonesia, Fiji Islands, Dubai etc.

Shivpad presently manufactures these products at its facility in Chennai where its team of experienced engineers ensures that Shivpad products are assembled and tested to meet the quality expectation of the clients.

Shivpad products are known to be highly reliable and long lasting and repeat orders from most of the clients using our equipments stand testimony of Shivpad's quality and excellent after sales service support.

In the year 2011, Shivpad was acquired by M/s. Jash Engineering Ltd – Indore and consequently is now a wholly owned subsidiary of Jash Engineering.

Established in 1948, Jash offers the most diversified product portfolio for the water and waste water industry. Jash is an industry leader in India in Water control gates, Fine and Coarse screens, Knife gate valves, Water hammer control valves, Energy Dissipating valves, Archimedean Screw pumps and Hydro Power screw turbines. Jash manufactures these products under technical collaborations with leading companies such as Schuette Industries service - Germany, Hollung - Norway, Weco Armaturen - Germany, Rehart - Germany, FSM Frankenberger - Germany, Stealth Valves- Canada and Mahr Maschinenbau - Austria.

Jash exports its products to over 30 countries worldwide. Jash presently has installed projects in USA, Canada, Britain, France, Germany, Belgium, Norway, Sweden, Kazakhstan, Turkey, Kuwait, Saudi Arabia, Jordan, Iraq, Oman, Bahrain, UAE, Sri Lanka, Bangladesh, Singapore, Malaysia, Thailand, Indonesia, Vietnam, Hong Kong and others.



Mechanical Screens under fabrication



Shivpad Office, Chennai



JASH Head Office - Indore

Association with Jash allows Shivpad to get access to the enhanced manufacturing capabilities, marketing strength and servicing network of Jash. To assist Shivpad in manufacture of large fabricated products, Jash has invested in a new fabricated products plant at Bardari, Indore. This plant has a built-up area of over 155,000 sq. ft. and is designed to handle products weighing upto 30 tonnes. This plant has a separate 65,000 sq. ft. area for fabrication of stainless steel products and separate 90,000 sq. ft. area for fabrication of carbon steel products.

This state of art manufacturing infrastructure along with proven technology enables Jash and Shivpad to offer reliable and high quality products at economical cost for Indian and International markets. With almost all the critical manufacturing facilities in-house, this plant gives Shivpad the flexibility to meet customised needs of the client with urgent deliveries whenever required.



Fabricated Product Plant, Indore



SHIV PAD
ENGINEERS PVT. LTD.

A Subsidiary of
JASH ENGINEERING LTD.



Screens

Flash Mixers

Flocculators

Clariflocculators

Pressure Sand Filters

Activated Carbon Filters

Chemical Dosing Systems

Water Treatment Plant

Screens

Oil Separators

Detritors for Grit Removal & Washing

Surface Aerators

Flash Mixers

Chemical Solution Agitators

Clarifiers

Clariflocculators

Thickeners

Dissolved Air Floatation Cells

Floating Decanters

Pressure Sand Filters

Activated Carbon Filters

Industrial Waste Water Treatment Plants

Reliable products for a Sustainable future

All process equipment are tailor made to suit each process application. The sizes and material of construction viz., Ferrous, Non ferrous, Rubber-lined, FRP Coated, Galvanized etc., can be always made available to suit the duty conditions and various options of the users.



Screens

Detritors for Grit Removal & Washing

Surface Aerators

Clarifiers

Thickeners

Trickling Filters

Digester Mixers

Floating Decanters

Pressure Sand Filters

Activated Carbon Filters

Sewage Treatment Plants

Milk of Lime Plants

- Table Feeders

- Rotary Drum Slakers

- Rake Classifiers

- MOL Storage Tank Agitators

General

Products

SCREENS

The first unit operation encountered in any Waste Water Treatment Plant is screening. According to the method used to clean the screen surface, these screens are designated as hand-cleaned or mechanically cleaned. Shivpad offers both Manual and Mechanical Screens for Coarse and fine screening applications.



Type SP-M2-C
Mechanical Coarse Screen
Installation at Kimdec, Malaysia

Multi-rake Mechanical Screen (Type SP-M2-C)

These mechanical screens are available from 10 mm and above spacing between bars for fine and coarse screening applications. The material of construction of these units can be either in stainless steel or carbon steel depending upon the application and the option of the user.

The chains used in Shivpad screens are specially designed roller chains which offer longer life and maintenance free operation. Built-in electrical overload control device protects the drive assembly and moving parts in case of system overload.

The auto operation can be implemented by timer control panel which will facilitate continuous cleaning operation at prefixed intervals.

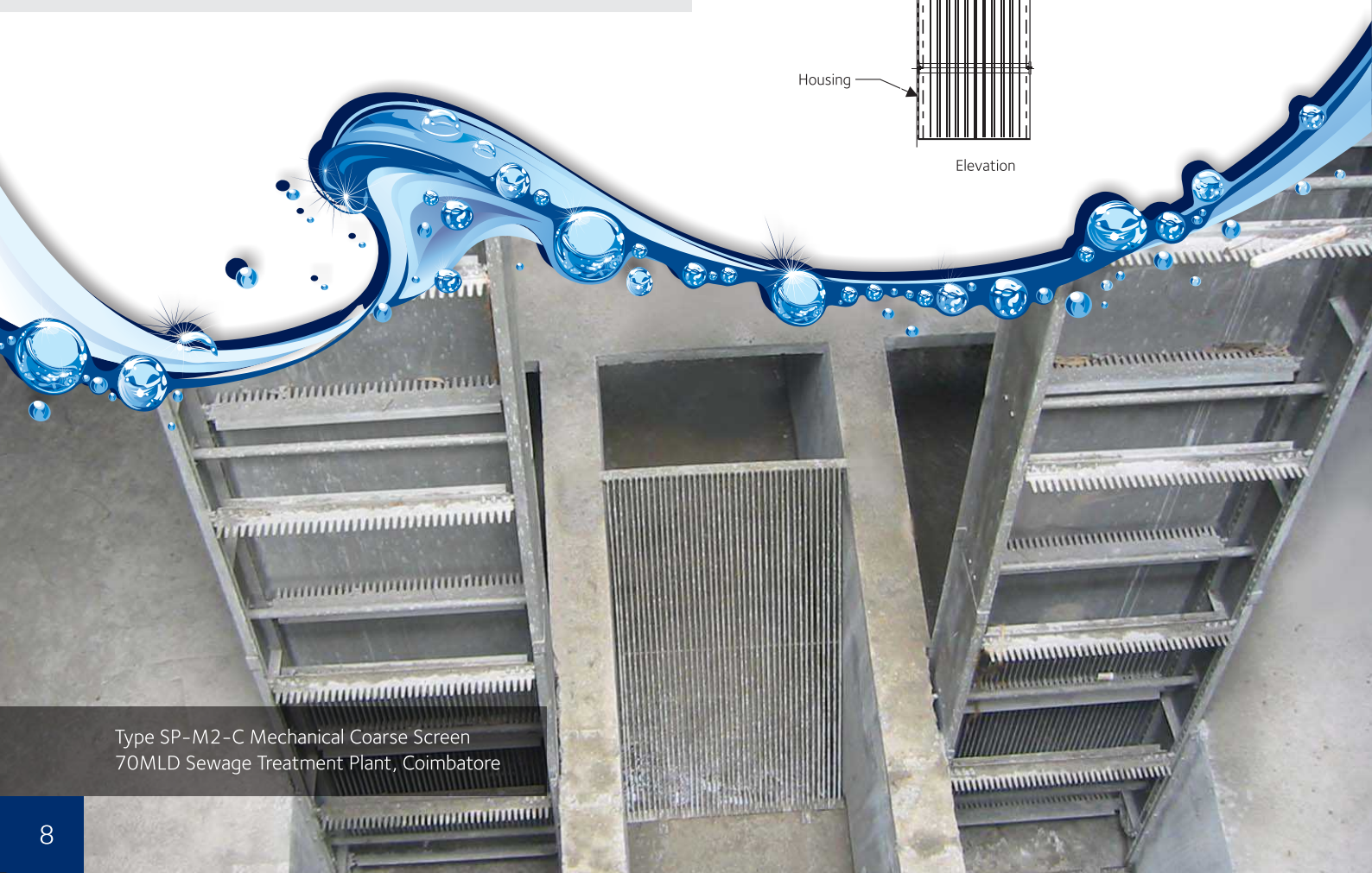
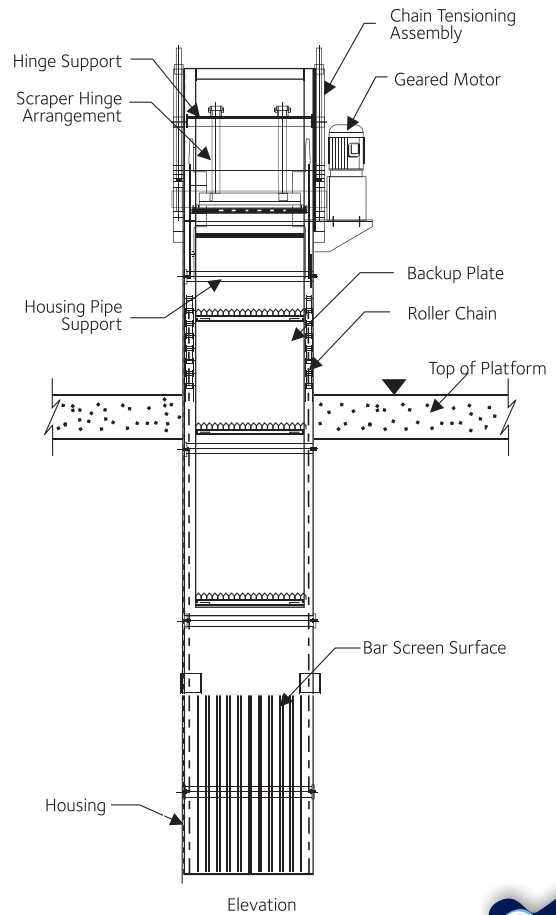

Type SP-M2-C Mechanical Coarse Screen
70MLD Sewage Treatment Plant, Coimbatore



Type SP-M2-C Mechanical Coarse Screen
87MLD Sewage pumping Station at Nanded



Type SP-M2-C Mechanical Fine Screen
Biotropic Engineering STP, Malaysia



Type SP-M2-C Mechanical Fine Screen
Taman Mas, Sewage Treatment Plant, Malaysia

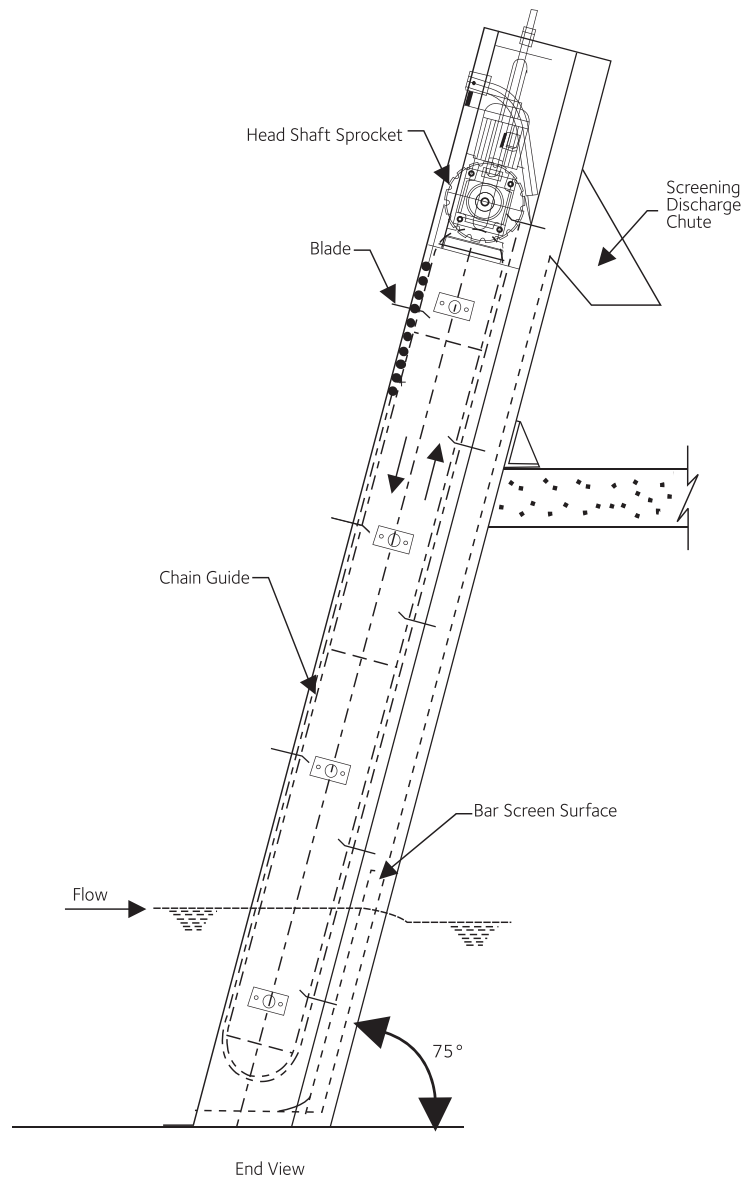

Rotary Mechanical Bar Screen Type SP-M1

This screen is made of bars curved to a radius and rakes revolve about a horizontal shaft, the axis of which is the Centre of curvature of the screen bars. The screenings are thus raked and discharged on to the drainage platform for disposal. The unit is equipped with timer control panel and no manual attention is required.

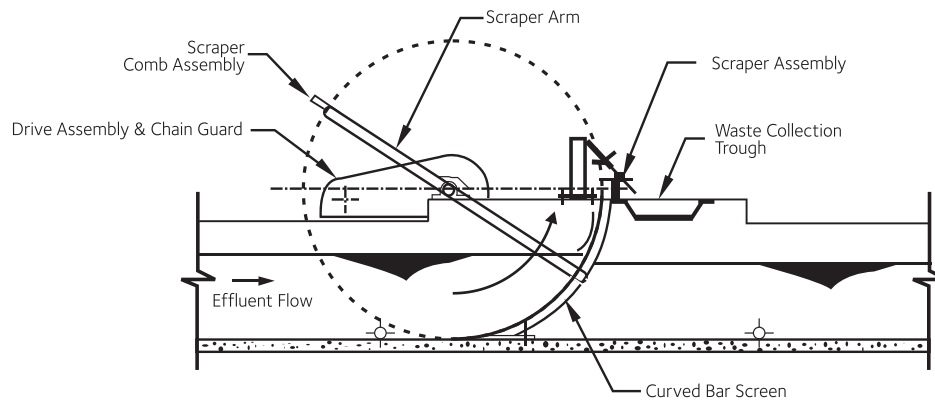

Wedge Bar Screen Type SP-WBS

These screens offer

- Low installation and operating cost
- No moving parts and hence less maintenance care
- High capacity per unit area of screen
- Finer separation to the tune of 0.5mm bar spacing

The feed is introduced into a feed box mounted atop of the unit and overflows from the parabolic shaped weir on to the screen surface. The weir ensures that the feed makes contact with the screening surface at an angle that will provide maximum screening efficiency. Oversized materials travel along the screen surface and are discharged at the end of the screen. Liquid together with any fine particles passes through the screen and discharges through the bottom outlet.

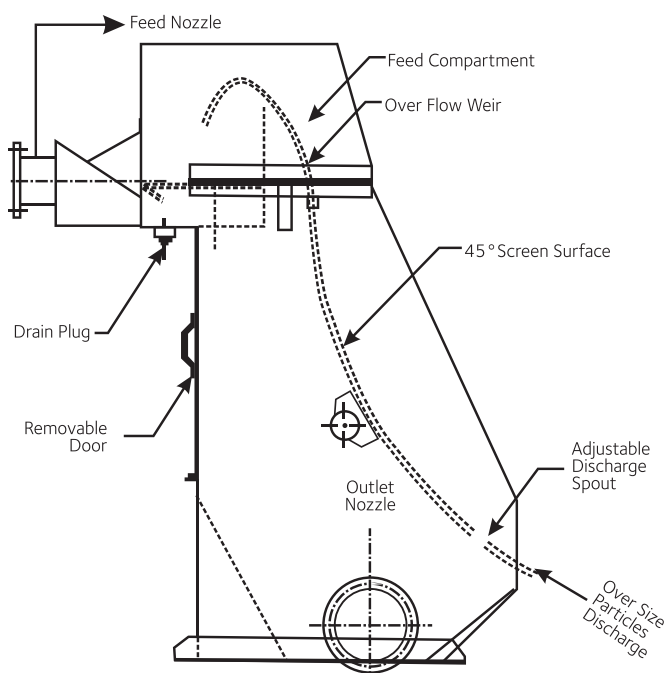

DETRITORS Type DT-STD

Detritors are Grit Collection and Washing Equipment best suited for horizontal flow type grit chambers.

These continuous mechanically operated grit collectors consist of a rotating outward raking mechanism to aid collection of grit at one point on the periphery of the tank from where they are moved up on an incline by either a screw or reciprocating rake mechanism. While passing up the incline, due to the combined gentle agitation and washing accomplished by the Screw or the reciprocating raking mechanism, organic solids are separated from the grit and flow back into the grit collection chamber.

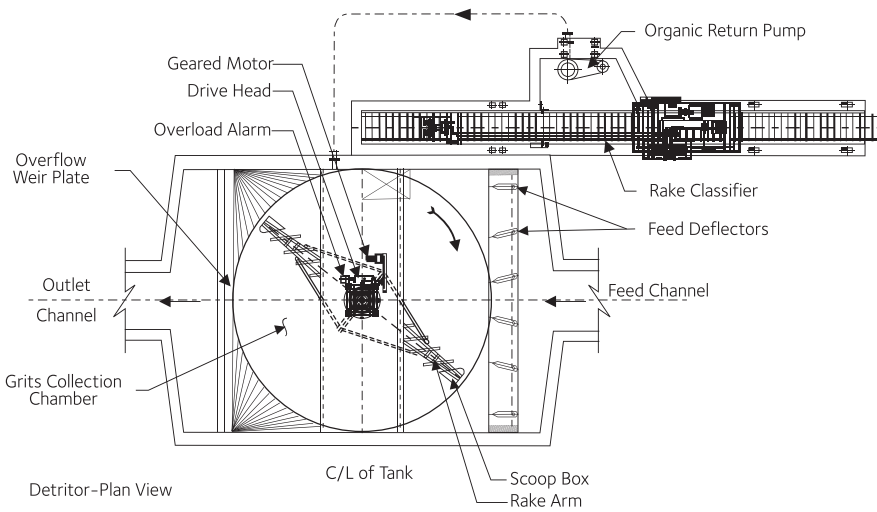

Screw Classifier Assembly
Nagole STP, Andhra Pradesh



Rake type Classifier Assembly
50MLD STP, Chandigarh

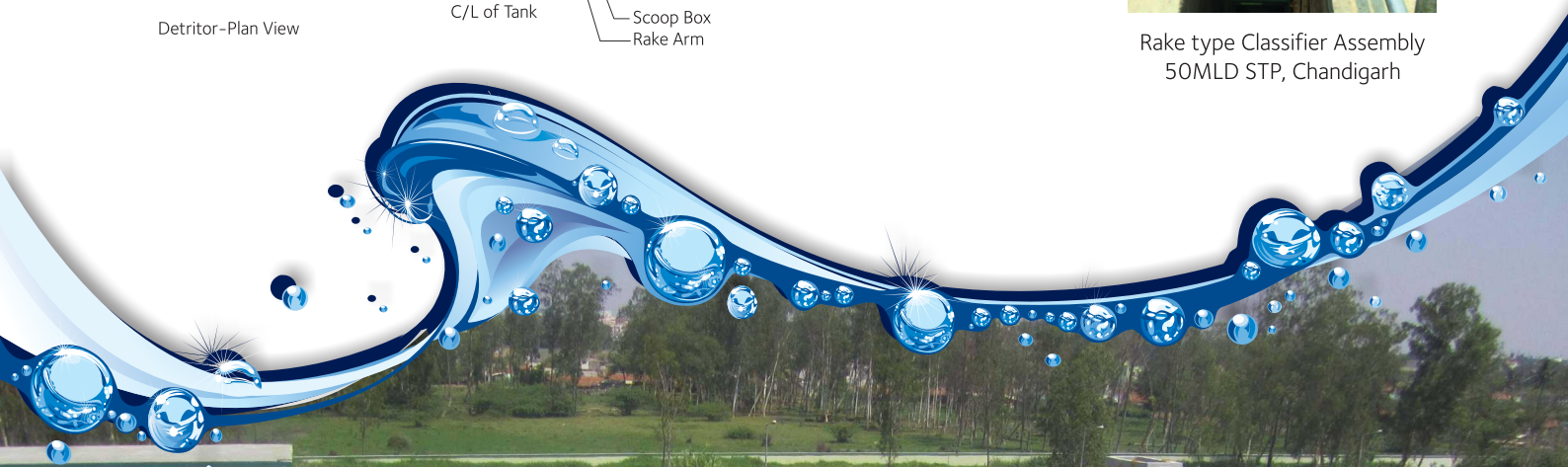

70 MLD STP at Coimbatore



By this method, a cleaner, well washed and drained grit is obtained from the screened influent as end discharge.

Grit free liquid that overflows from the collection chamber simplifies the downstream treatment process further.

The organic return pump provided ensures transfer of waste water from Classifier compartment back into the collection tank.

Shivpad offers Detritors from 3m to 12m square range.

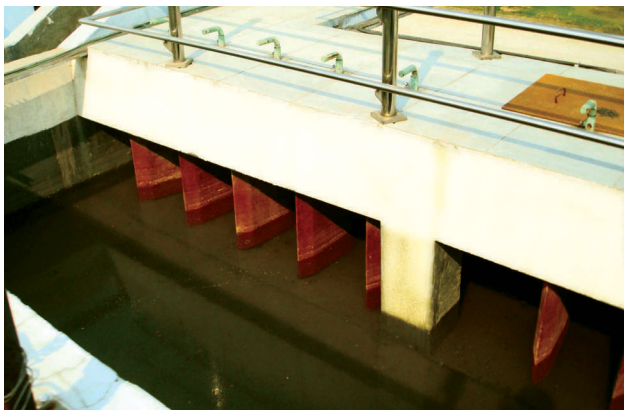

Feed Deflectors



Organic return pump

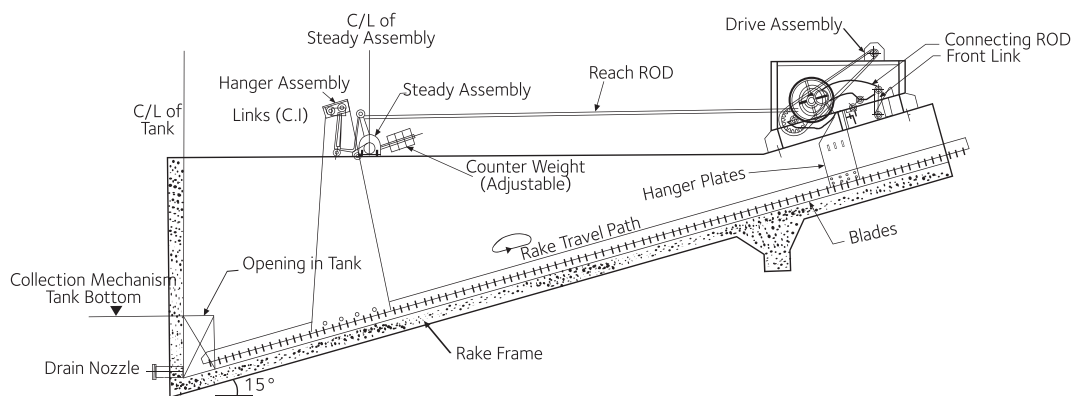

Rake Classifier - Sectional Elevation

CLARIFLOCCULATORS

Shivpad Clariflocculators incorporate the Flocculator and Clarifier in one compartment unit. Agglomeration of the destabilised colloids is achieved as a result of particle transport in the inner flocculation unit. Clarification occurs in the outer clarifier unit.

Flocculation, radial and upward flow sedimentation and positive sludge removal combined in a single tank operation are the salient features.



Type SPF-A

Shivpad offers Clariflocculators of Type SPF-A from 30m to 60m diameter range. These units are peripheral driven rotating bridge type with integral flocculator drive assembly.

Vertical Paddles connected to flocculator arms are driven by an independent drive anticlockwise whereas another set of paddles connected to clarifier arms rotate clockwise in much slower speed which provide gentle mixing enhancing flocculation of the feed suspended solids.

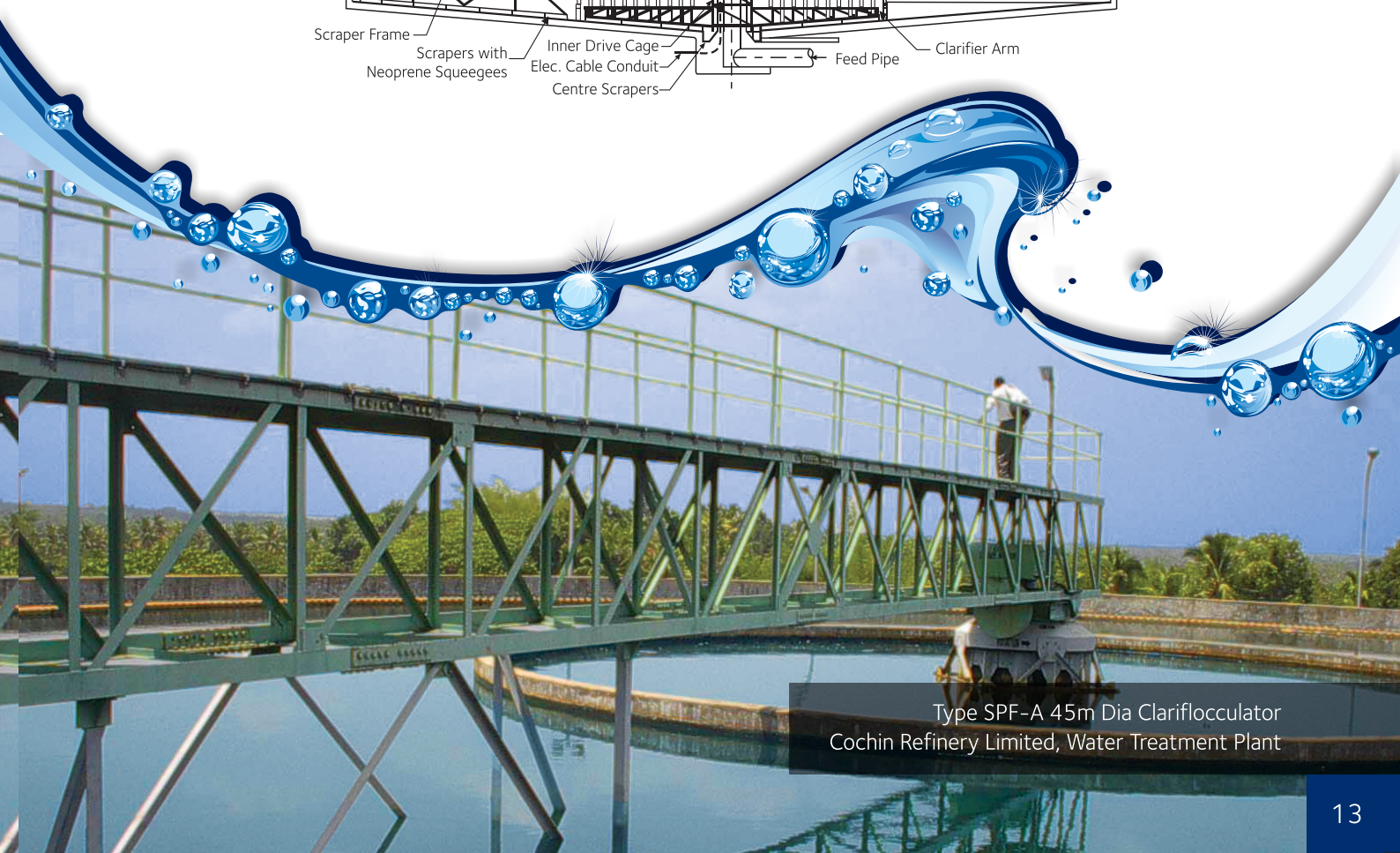
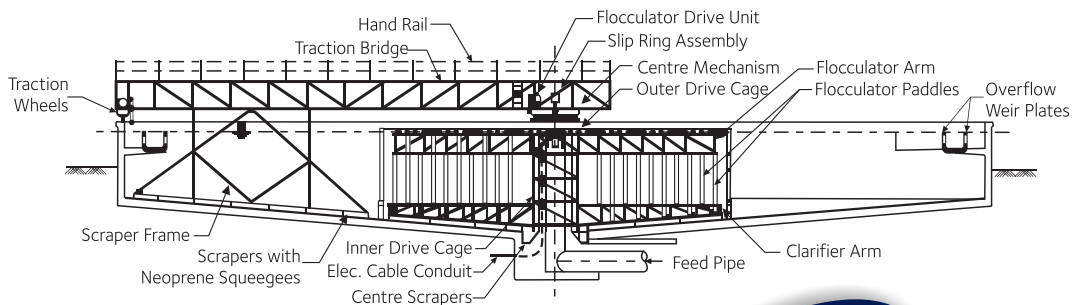
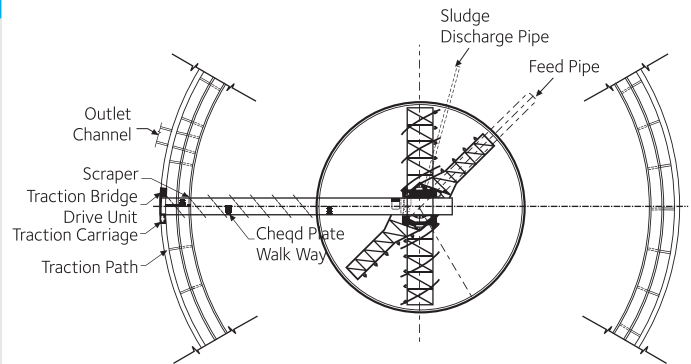

Type SPF-A 45m Dia Clariflocculator
Cochin Refinery Limited, Water Treatment Plant

Type SPF-B 23m dia Clariflocculator at TWAD board Water Treatment Plant, Tiruvannamalai



Type SPF-B

These units are peripheral driven rotating bridge type combined with independently rotating flocculator units that provide gentle stirring for flocculation. Shivpad offers Clariflocculator of Type SPF-B from 10m to 60m diameter range.

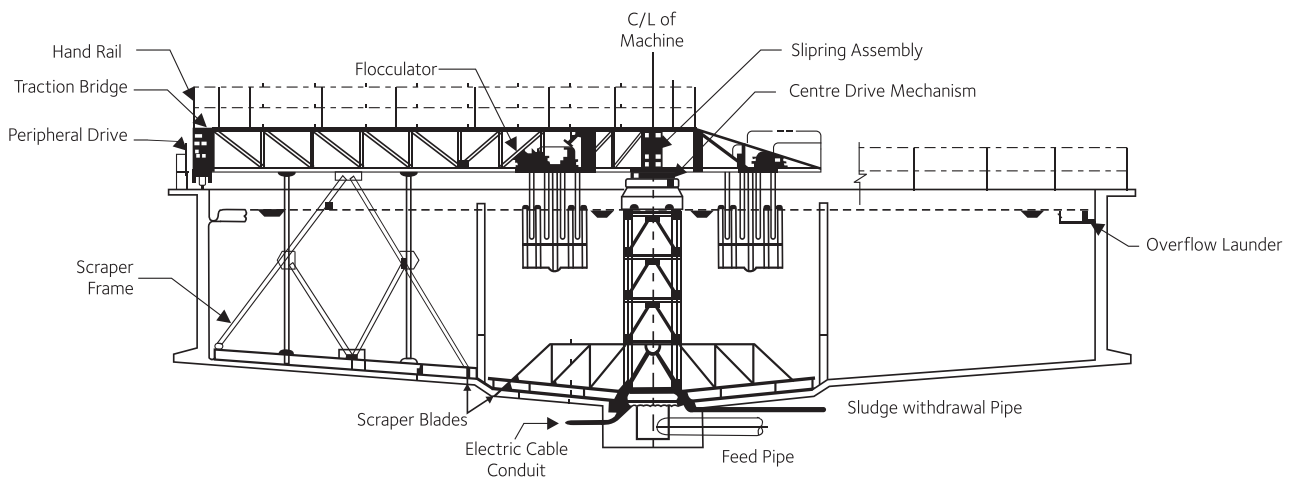

Type SPF-C

For Clariflocculators of smaller sizes, Shivpad offers units of Type SPF-C. These units consist of the flocculator paddles attached to a central shaft that rotates at a slow speed and the fixed paddles are supported from the bridge. There are independent drive arrangements for the flocculator and clarifier. These units are provided with fabricated steel flocculator compartment suspended from the bridge whereas the other model units are with RCC / brickwork flocculator compartments. Shivpad offers Clariflocculators of Type SPC-C from 6m to 15m diameter range.

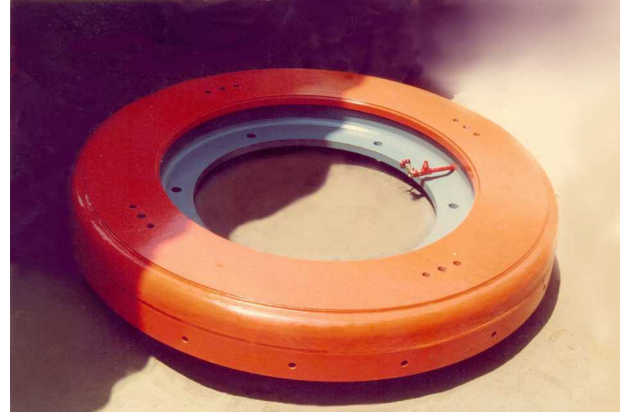

Turn table assembly for SPF-B Clariflocculator

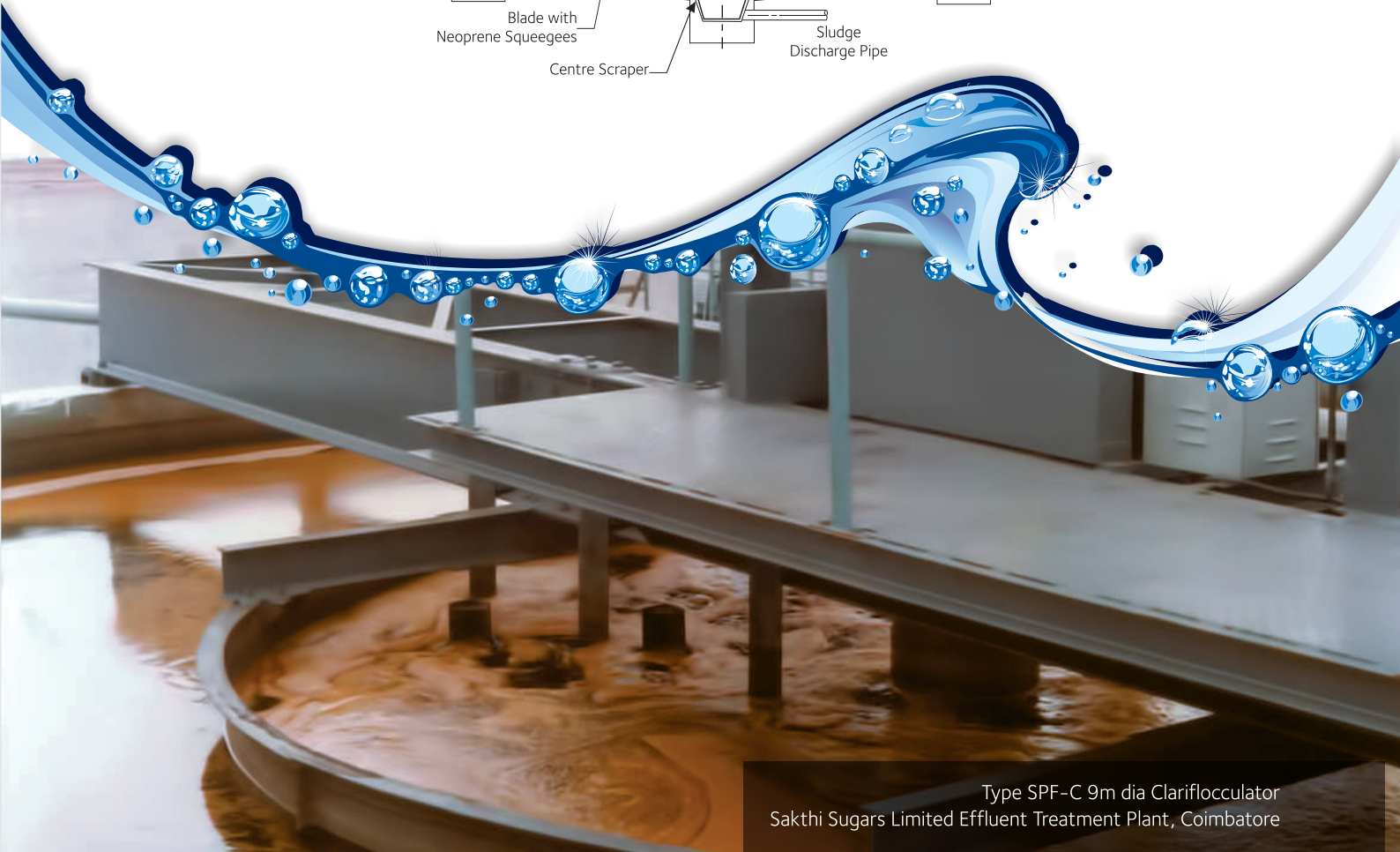
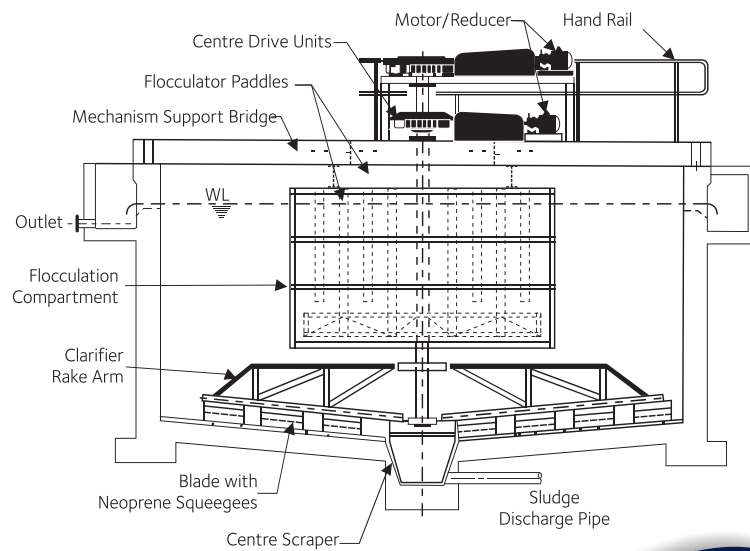

Type SPF-C 9m dia Clariflocculator
Sakthi Sugars Limited Effluent Treatment Plant, Coimbatore

SURFACE AERATORS

Shivpad Surface Aerators are available for Municipal Sewage & Industrial waste water treatment applications. They are generally recommended for activated sludge process, aerobic digestions or aerated lagoons as well as for pre-aeration. Prime objective is to offer mechanically trouble-free equipment maximising oxygen transfer and mixing under variety of conditions.

Shivpad offers both Slow Speed Fixed type Surface Aerators and Slow Speed Floating Surface Aerators. Oxygen transfer ranges from 1.6 to 1.8 kg/HP-hr at standard conditions.

Slow Speed Fixed Surface Aerators Type SP-SA-1

The slow speed fixed type Surface Aerators have gear reduction between the motor and the impeller. These units have no mechanical complications and are preferred to other types of Aerators since they produce lesser shearing of the biological floc. Shivpad Surface Aerators are available in ranges from 3HP to 75HP. The type of impeller varies with the rating of the aerator. The impellers are dynamically balanced for optimum performance.

The impellers are in both conical vane type and pitch blade design and these perform by drawing the bulk liquid towards the impeller and dispensing it upwardly and outwardly with minimum energy dissipation. The liquid is dispersed through the air as fine droplets. This results in an

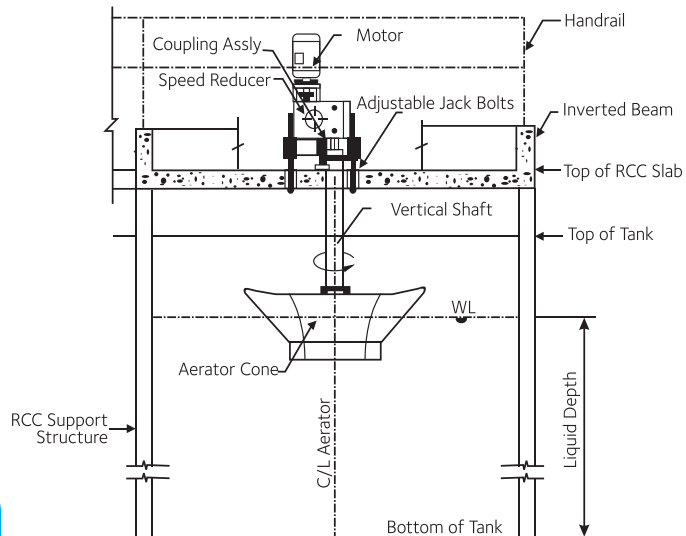

increased interfacial surface area per unit volume of the liquid enhancing entrainment of air, as the rate of oxygen transfer is directly proportional to the interfacial surface area. The fine droplets with the entrained air fall back to the bulk fluid and are circulated below the surface. Air and oxygen transfer occur both at the surface of the droplet and at the surface of the bulk liquid. Also the aerator provides effective mixing to keep the biomass in suspension throughout the aeration tanks and lagoons.

Every Unit is provided with a facility to adjust the impeller submergence level in field to ensure the performance with maximum efficiency.



Fixed Slow Speed Type Aerators
4 MLD STP at Surya Nagar, Bangalore

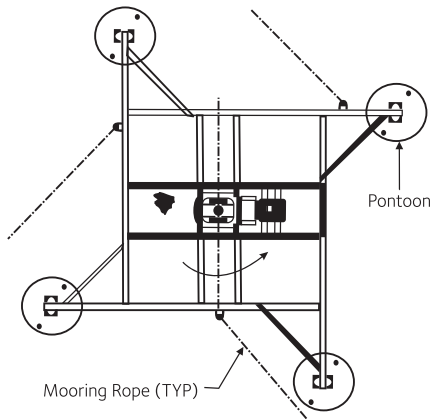

In case of fixed type Surface Aerators the impeller submergence level can be mechanically adjusted by a jacking arrangement whereas floating aerators have facility to adjust the impeller submergence level by means of appropriate counter weight addition in floats.

Slow Speed Floating Surface Aerators Type SP-SA-2

The slow speed floating Surface Aerators are similar to the slow speed fixed Surface Aerators as far as the main drive and impeller assemblies are concerned. The total assembly is mounted on a float rig frame which is located in the aeration tank or lagoon by mooring ropes.

The pontoons are filled with high density polyurethane foam and sealed from the environment. The floating surface aerators are mostly considered in tankages where the liquid level is not constant and varies from time to time depending upon the process or where a rigid support would be impractical.

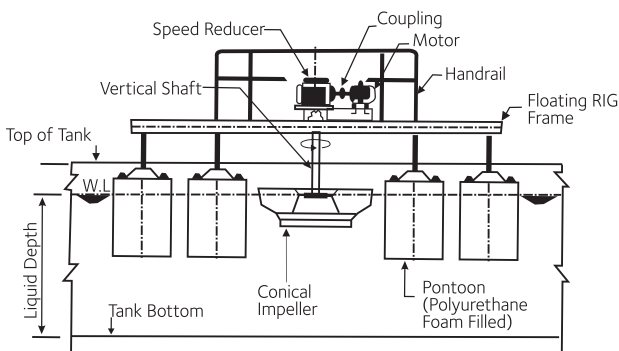

HP Selection Chart for Surface Aerators

Motor HP	Zone of Influence Dia. in Meters		Liquid Depth in Meters	
	Min	Max	Min	Max
3	4.5	8	1.3	2.5
5	5.5	10	1.6	2.8
7.5	6	12.5	1.6	3.0
10	7.5	14	1.7	3.2
15	8	15	1.7	3.3
20	9	18	1.8	3.7
25	10.5	20	1.9	3.7
30	11	22	2.0	3.9
40	12	24.5	2.2	4.2
50	13	27	2.5	4.5
60	14	28.5	2.7	4.8
75	16	31	2.8	5.1



Slow Speed Floating Surface Aerator Type SP-SA-2
IPOH STP, Malaysia

CLARIFIERS

Shivpad Clarifiers provide better suspended solids removal in primary treatment and also aid solid liquid separation of biologically treated secondary effluent. These units help to achieve a superior quality effluent as well as to maintain a high underflow concentration.

Primary Clarifiers serve to

- Remove settleable solids
- Remove free oil, grease, and other floating materials
- Reduce the organic loading to subsequent biological units

Secondary Clarifiers aid in

- Solid liquid separation of biologically treated effluent
- Thickening the under flow sludge concentration desirable for efficient operation or to prevent process upsets of activated sludge system
- Achieving an effluent of excellent quality

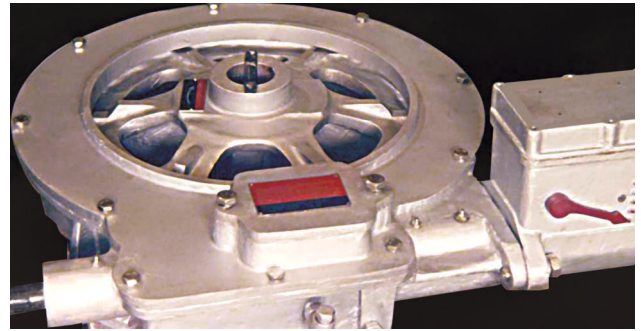

Drivehead with electro mechanical overload alarm assembly

Bridge mounted central driven type Type SPC-A

Bridge truss spans the full diameter of the tank. Feed well, drive and rake mechanisms are supported by the bridge truss. Worm and worm wheel type drive head powers a vertical centre shaft carrying the rake arms. Feed enters through the central feed well. Clear overflow is collected in a peripheral launder whereas the settled solids are desludged from the central sludge pocket. Shivpad offers Type SPC-A Clarifiers from 3m to 20m dia range.

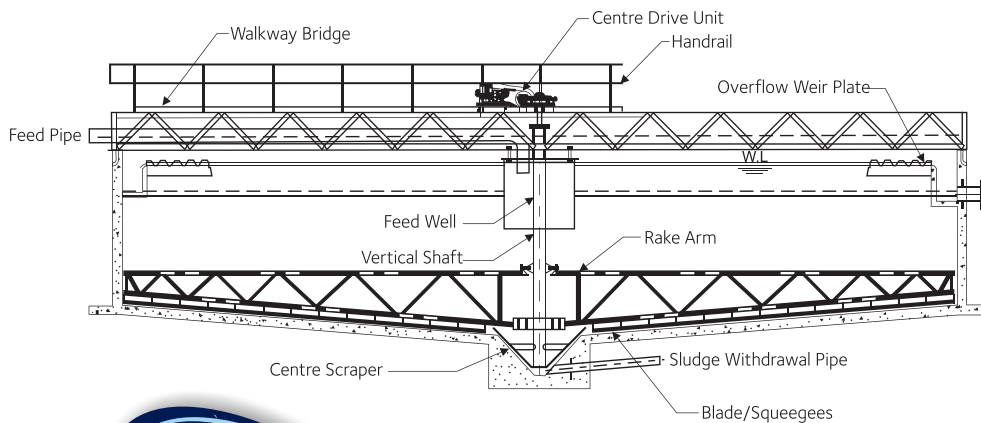

Type SPC-A Clarifier, 2000 Cu.m/day ETP
at Bannari Amman Sugars Ltd., Nanjangud, Karnataka.

Type SPC-B 23m dia Peripheral driven Traction Clarifier
at Doha STP, Qatar
Material of Construction: SS316L

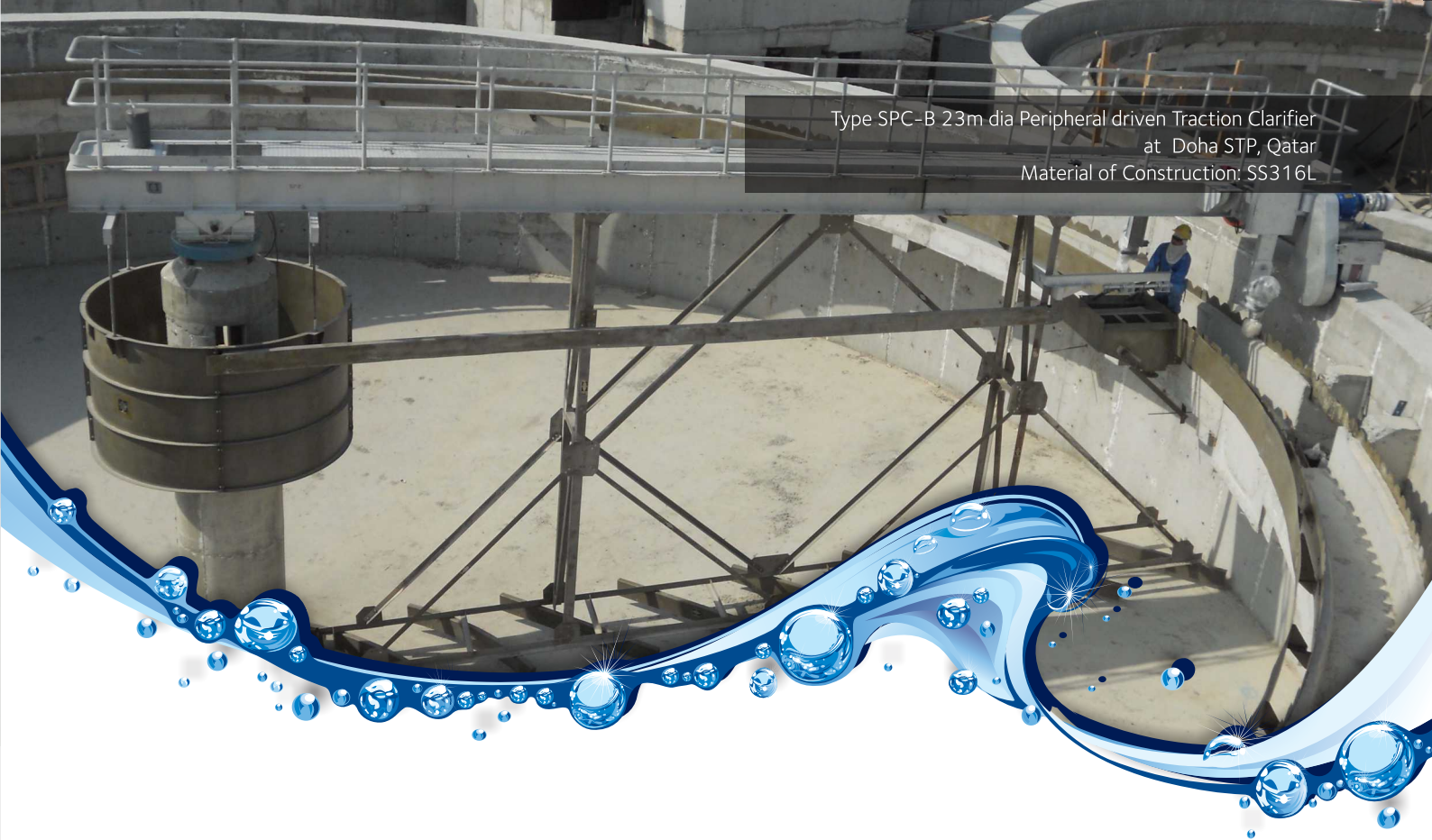

Peripheral Driven Traction Clarifier Type SPC-B

Stationary centre pier partially supports the rake mechanism and serves as pivot about which the rake rotates. Traction Bridge is supported on turn table at one end and driven by traction carriage assembly at the other end.

Feed is introduced into a feedwell at the centre of the tank. The rakes supported from rotating bridge scrapes and settled solids collect in central sludge pocket. Clear overflow is collected in a peripheral launder and the settled solids are discharged from the central sludge pocket.

Shivpad offers Type SPC-B Clarifiers from 15m to 50m dia range.



Type SPC-B 21m dia Peripheral driven Traction Clarifier
at Crimson STP, Malaysia.

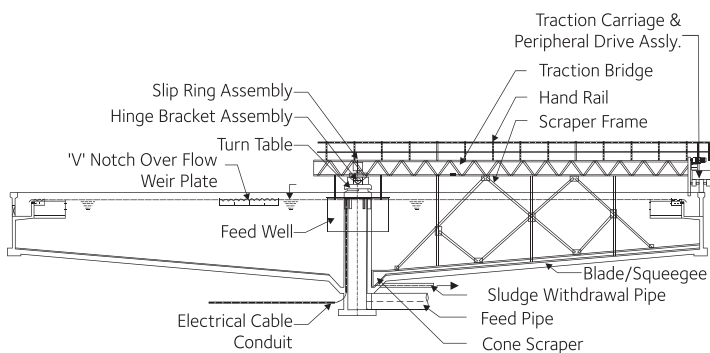

Type SPC-B Peripheral driven Traction Clarifier drive assembly,
Skimmer Assembly and Weir cleaning device – Doha STP , Qatar

Type SPC C Centre Pier type

The drive mechanism is supported by a stationary centre pier. A structural steel cage suspended from the drive mechanism carries the rake arms. A structural bridge extending from the centre to periphery of the tank serves as walkway. Feed is given to the feed well at the centre of the machine. Clear overflow is received at the peripheral launder and sludge raked by the rake arms is discharged from the sludge pocket.

Skimmers are provided whenever duty conditions demands and are assembled with the central shaft and scraper arm supports. The surface skimmer arms provided with rubber flaps help remove floating materials and grease from the liquid surface. The skimmings are collected in a scum trough supported on the tank inner wall which will ultimately drain the skimmings.

Shivpad offers an overload alarm protection to provide positive warning to protect against equipment damage should excess loading occur. The electro mechanical overload alarm is mounted on the worm shaft end of the drive head. Alarm and drive cut-off switches are provided to warn of an impending overload or to stop the equipment if the capacity of the drive exceeds.

Shivpad offers Type SPC-C Clarifiers from 20m to 50m dia range.



Type SPC-C: Centre Pier Type Clarifier

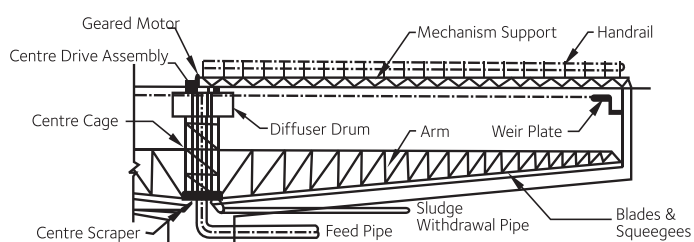

Type SP – STD Clarifier Mechanism for Rectangular Sedimentation tank

Rectangular Tank Sludge removal equipment offered by Shivpad consists of a pair of endless conveyor chains. Attached to the chains at regular intervals are scraper flights of wood or steel extending the full width of the tank. These scraper flights travel from feed end to the sludge collection end at a speed of approx. 1.2m per minute. The solids settling in the tank are scraped to sludge hoppers by the scraper flights.

Supporting arrangements for the scraper plates are guide rails installed on either side of tank walls and also on the tank floor. Easily replaceable ductile iron guide blocks assembled to the sides and bottom of scraper flights facilitate minimum wear and increase the operating life of the mechanism. If the scum removal becomes necessary, the design of Shivpad has provision to offer the equipment with same scraper flights carrying out scum removal operation at liquid surface on their return level. Most common scum draw-off facility is offered with horizontal slotted pipe that can be rotated by a lever or by a gear & headstock assembly. Sizes offered: 4m wide max X 20m long max.



Type SP-STD: Rectangular Clarifier, Kuantan STP, Malaysia

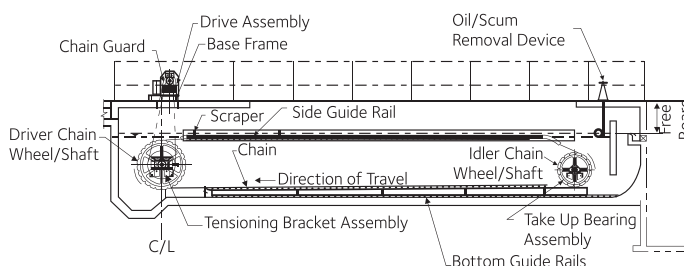

THICKENER Type SPT-A & Type SPT-C



Motorized lifting device with slip ring assembly

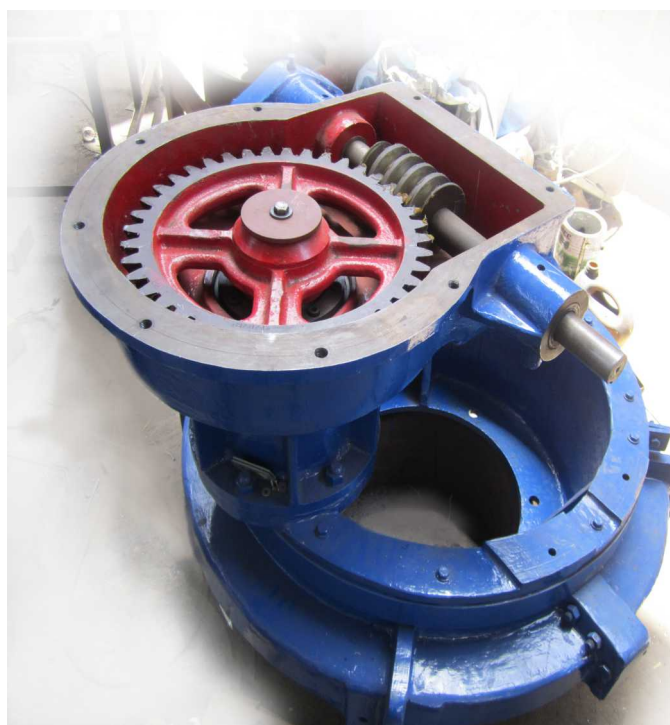

2 stage reduction centre mechanism assembly
Type SPT-C Thickener Mechanism

Shivpad Thickeners function essentially to increase the solids content of sludge from Clarifiers or any other sedimentation tanks by removing a portion of the liquid fraction. This thickening of solids will help decrease sludge volume which in turn is beneficial to subsequent treatment processes. These units are also available in constructional features similar to Clarifier units i.e. both constructions with bridge spanning tank dia. of Central Driven Type SPT-A & Centre pier Half Bridge Type SPT-C

As a standard constructional feature, Shivpad Thickeners are provided with electro mechanical overload alarm/motor trip device to protect the drive mechanism from possible damage due to overload. The switches provided in the over load alarm housing get activated due to the axial shift of drive head worm shaft during overload conditions and operate the alarm first and motor trip later, if no further attention is given for desludging. The overload alarm and motor trip torque limits can be manually pre-set to facilitate equipment operation to suit the user's option.

Shivpad Thickeners are also available to meet out tougher operating conditions, especially acidic effluent handling. The steel rubber lined tank with steel rubber lined Thickener structurals provided ensures absolute protection for operation under acidic conditions.

Manual or motorised lifting devices can be optional for the user of Shivpad Thickener Mechanisms. These devices are designed to lift and lower rake arms during overload conditions. All these mechanisms are factory assembled for ease of erection and adjustment in field.

Shivpad offers Thickeners of Type SPT-A from 3m to 25m dia range and Thickeners of Type SPT-C from 20m to 50m dia range.

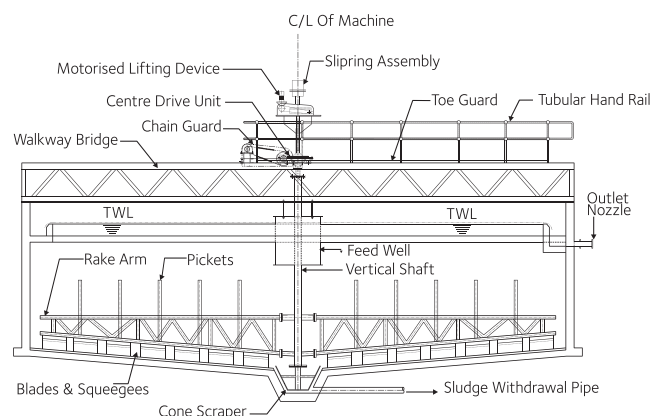

Thickener Type SPT-A

TRICKLING FILTER Type TF-STD

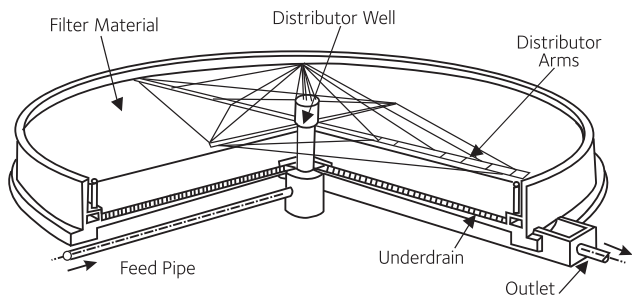

Turn table assembly

Shivpad Trickling Filters find extensive use in aerobic attached – growth biological treatment process to remove organic matter found in waste water especially in Sewage Treatment plant.

These units consist of a bed of highly permeable media to which micro-organisms are attached and through which waste water is percolated or trickled. The organic material present in the waste water is degraded by a population of micro-organisms attached to the filter media.

The filter media has high surface area per unit volume, is low in cost, has high durability and does not clog easily. The filter media usually consist of sized rocks varying in size from 50 to 100 mm. Alternately filter media can be in plastic as well.

Shivpad Trickling Filter is a self-propelled turn-table unit. It is available with either two or four arms construction. The entire distributor well and distributor arms assembly rotates on a frictionless free-rotating cast iron turn table.



48m dia Trickling Filter at Atladra STP – Baroda



10MLD STP Trickling Filter at Allahabad

DIGESTER MIXERS Type DM-STD

Proper mixing is one of the most important considerations in achieving optimum process performance in sludge digesters.

Shivpad offers single or multiple draft-tube Digester Mixers through which the sludge is circulated by a turbine mixer located within the tube. These units are specially designed to increase the efficiency of digestion and to yield a uniformly digested product. These Digester Mixers provide effective mixing of incoming sludge with the digested sludge and increases the rate of digestion.

It accelerates the release of generated gas and assists in maintaining better pH control as well.

The propellers are offered in a special manganese bronze construction or stainless steel for increased life of operation. Vertical shafts are generally in forged steel construction. The housing can be either in cast iron or in carbon steel construction. Intermediate bearings are provided depending upon the length of housing. Drive arrangement shall be either direct motor driven or belt driven arrangement as opted by the user.

Shivpad offers Digester Mixer Type DM-STD from 5HP to 60HP range.



Anaerobic Digester Tanks with Multiple Draft-Tube Digester Mixers

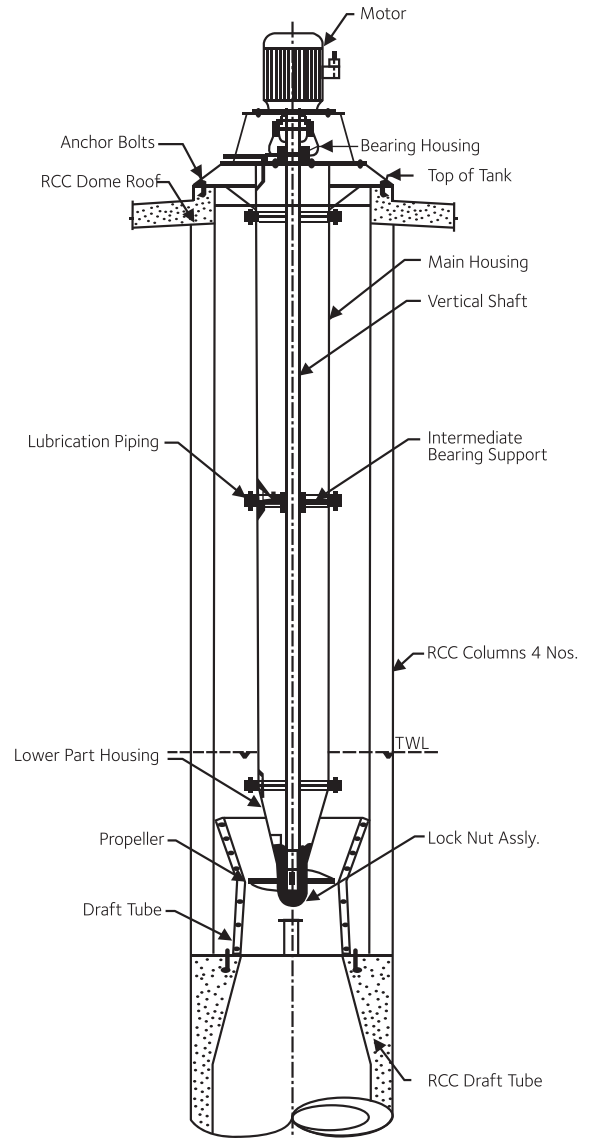

Typical Cross-Sectional view of Digester Mixer



FLOATING DECANTERS

Type FD-STD

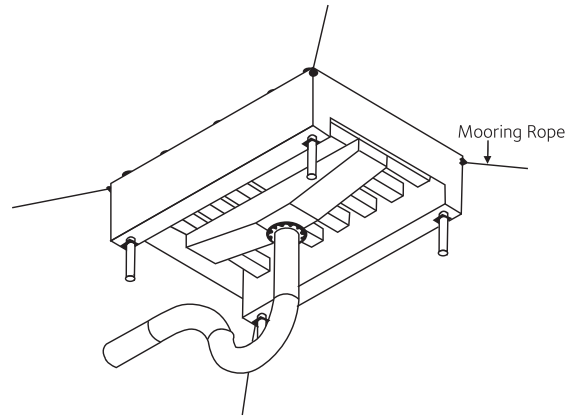
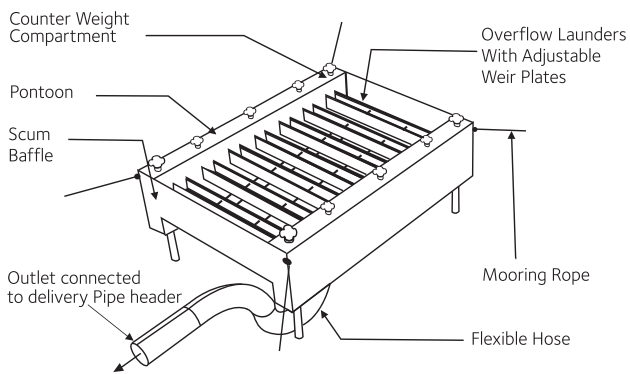

Shivpad Gravity Weir type Decanters have been developed exclusively for Sequential Batch Reactor System based Waste Water Treatment Plants though these can be used generally for other decanting applications as well.

The advantage of Shivpad Gravity Weir type Decanters lies in the tailor-made, extremely durable, energy saving and more economical and efficient system than the conventional power driven decanter mechanisms. This means considerable savings in operation, maintenance by way of no inventory for spare parts and related investments. Shivpad offers Decanters from 50cum/hr to 600 cum/hr capacity. In case of higher capacity requirements, multiple decanters of suitable capacities can be installed in a single tank.

Constructional Features

Material of construction being stainless steel to keep away from corrosion problems, the decanter has a pair of

polyurethane foam filled pontoons with adjustable weir plates and also provision to add counter weights at all four corners for leveling and achieving required level of submergence. These units are carefully engineered to suit each and every application and duty conditions to fulfil all the customer requirements.

The unit floats on the liquid surface due to buoyancy and draws-off decanted liquid from the top surface when the delivery pipe permits free-flow.

Also the baffles provided at both ends and the body of pontoons above water surface avoid escape of scum and other floating materials through the overflow.

Installation

Depending upon the liquid draw off levels, either mooring ropes anchored to the tank walls or guide support facilities are provided. The unit travels up & down depending upon the tank liquid level controlled either by mooring ropes or sliding over guide supports.

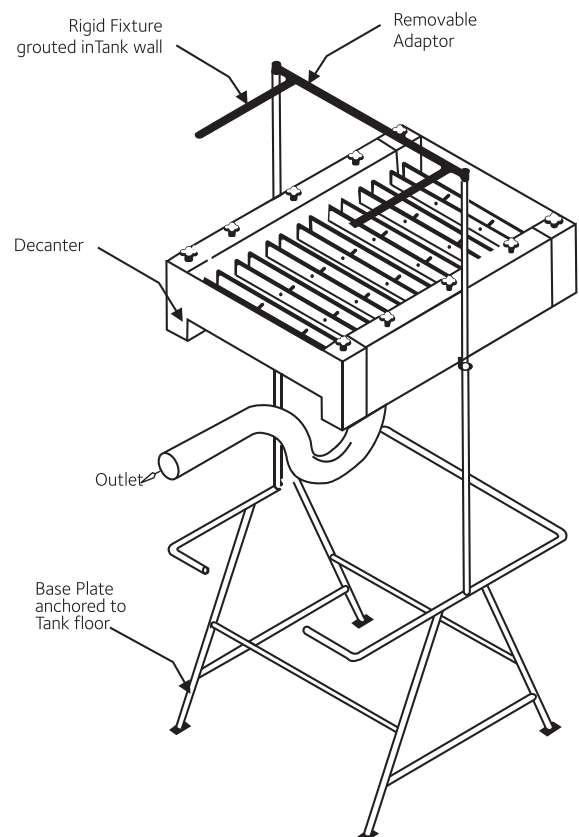
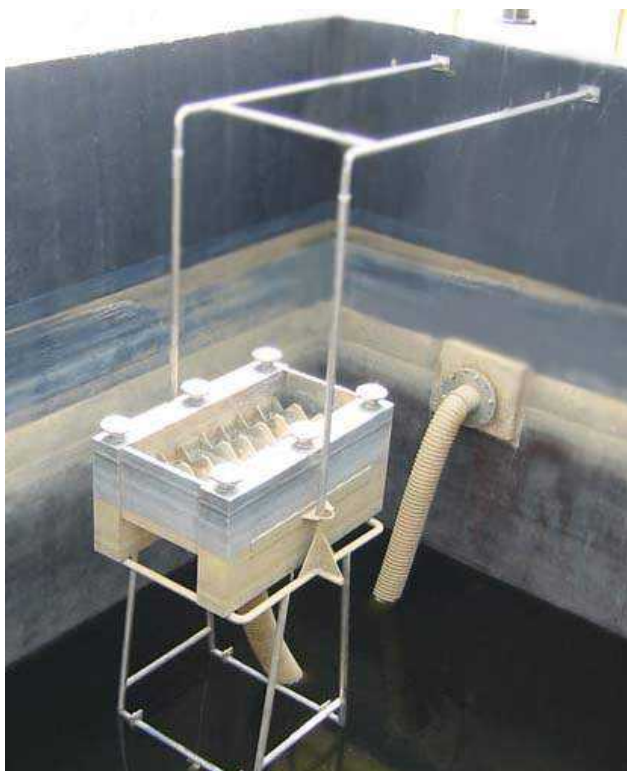

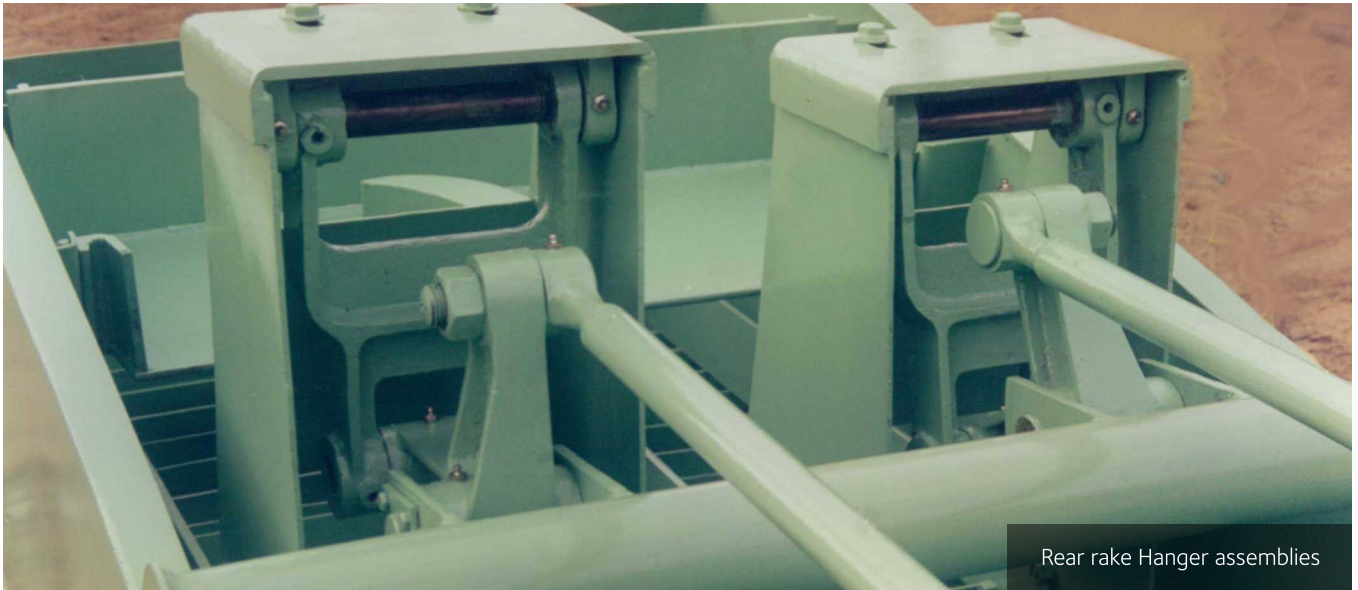

Rear rake Hanger assemblies

Shivpad Lime Classifiers are basically straight line reciprocating Rake Machines supplied mainly to sugar, paper & pulp industries for two product separation.

These units are available both in Single and Twin compartment construction. The operation of both Single and Twin compartment classifiers is simple and continuous. The Reciprocating Classifier Rake transports the grit up the inclined deck to a water spray. Washed and drained, the grit is discharged at the upper end. The Grit free liquid overflows from the lower end and is taken to further process.

The features of Shivpad Classifiers accomplish fully balanced harmonic motion and full load raking strokes.

PROVEN ADVANTAGES

Efficiency

Ensures proper Grit settlement, washing and classification

Low Cost and Compact Installation

Shivpad Classifiers can be erected on a simple concrete slab foundation or even on a steel support platform.

Low Maintenance

All bearings are strategically positioned above corrosion level and are easily lubricated. The linkages have been designed for rugged and dependable service.

Simple operation

Periodic checks on lubrication shall be adequate to ensure a trouble free operation.



Twin Rake Classifier Assembly - View from Grit Discharge end

PRODUCTS FROM JASH

Jash Engineering Ltd., Indore is the parent company of Shivpad and is a market leader in India in the Water Control gates, Fine Screens, Knife gate valves and Water hammer control valves business. In addition to these products Jash now also offers Hydropower Screw turbines, Archemedian

Screw Pumps and Travelling band screens for the water industry. With the wide range of products offered both by Jash and Shivpad, together we are able to offer the most comprehensive product range in India for the water industry.

Water Control Gates / Sluice Gates / Penstock Gates

Application: Isolation of flow in and out of a closed conduit or an open channel, Controlling level of liquid in a tank/channel, Drainage from outfall structures and plant to river/sea.

Types: Sluice gates, Open channel gates, Slide gates, Weir gates, Flap gates, Roller gates, Stop logs etc

Manufacturing Standards: IS13349, IS 3042, AWWA C560, AWWA C561, AWWA, C562, AWWA C563, BS 7775

Material of Construction: Cast Iron, Ductile Iron, Alloy Cast Iron, Stainless Steel, Aluminum, Fibre Reinforced plastics, HDPE, Composite and Carbon steel.

Sizes: from 100x100 mm to 4000x5000 mm

Operation: Manual, Electric, Pneumatic and Hydraulic



Knife Gate Valves

Application: For pressure tight isolation of solid liquid mixes in pumping stations and treatment plants.

Types: Bonneted valves Series MONO, MONO-A & MONO-T, Non Bonneted valves series ZFT-STD & ZFI

Applicable standards: AWWA C520, MSS SP 81

Material of Construction : Cast Iron, Ductile Iron, Alloy Cast Iron, Stainless Steel, Cast steel, Duplex, Super Duplex.

Sizes: from DN 80 to DN 600 for MONO series and from DN 50 to DN 3000 for ZFT & ZFI series

Operation: Manual, Electric, Pneumatic and Hydraulic

Fine Screens

Application: Screening of very fine floating waste coming with water and waste water in treatment plants.

Types: " SCREENMAT" Step Screens, "Roto clean" Drum Screens, "MM2MM" Multi raking screens, "Roto brush" super fine screens.

Material of Construction: Stainless Steel.

Spacing: Minimum 2 mm for fine screens & upto 0.25mm for superfine screens.

Operation: Motorized.

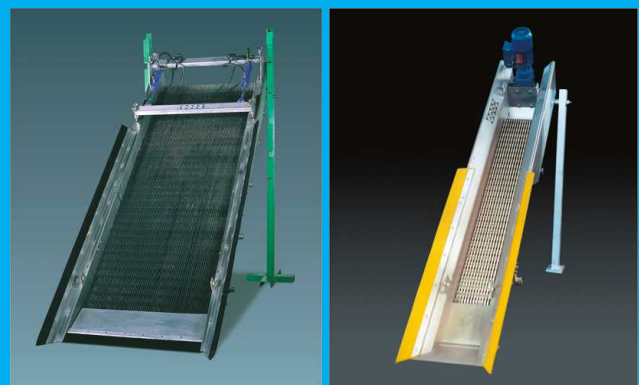

“SURESEAL” Water Hammer Control Valves

Application: Control water hammer / pressure surges in rising mains/ cross country pipelines.

Types: Zero Velocity Valves – Self actuating, spring loaded for best closing characteristic; Air Cushion valve- self actuating for providing non- slam rejoining of water column. Both valves as described in CPHEEO manual

Material of Construction: MS Fabricated.

Sizes: Zero Velocity Valves from DN 100 to DN 2500 (higher can be offered after study), Air Cushion Valves from DN 100 to DN 300

Operation: Self Actuating



18.5kW Hydropower station at IMC, Indore

Hydropower Archimedean Screw Turbines

Application: To generate renewable energy using water heads as low as 1 meter. Most suitable for power generation at outfall of sewage treatment plants

Types: CR : Compact Type, CS : Totally Enclosed Compact Type, BS : Semi-Compact Type, SH : Steel trough for Casting

Material of Construction: Carbon Steel.

Power Generation: from 5 kW to 500 kW

Archimedean Screw Pump

Application: For pumping of waste water / storm water in application involving high capacity variable discharge at low heads of up to 10 meters.

Material of Construction: Carbon Steel.

Discharge Capacity: From 0.1 Cumecs to 10 Cumecs.

Static Head: From 1 m to 10 m.



For more details about these products please visit www.jashindia.com or send email on info@jashindia.com



Chemical dosing station – PT Poly Prima – Ciligon, Indonesia.



STP at Damansara, West Malaysia



Distillery ETP at Thiru Arooran Sugars, Tamilnadu



STP at Parit Bunter – West Malaysia



Ramalingeshwar STP – AP



Sugar Plant ETP at Nanjangud – Karnataka



A Subsidiary of
JASH ENGINEERING LTD.



SHIVPAD ENGINEERS PVT. LTD

Plot No. 3/86-E, ATC Road, 2nd Main Road,
Ambattur Industrial Estate, Chennai 600 058.
Ph: +91-44-48606201 / 48606203
Email : info@shivpad.com

www.shivpad.com

Pictures shown are general, unless specific job names are listed.
Manufacturer reserves the right to depart from the catalogue specifications and illustrations.



JASH ENGINEERING LTD.

Plot No.31, Sanwer Road, Sector C,
Industrial Area, Indore, 452015 Madhya Pradesh, India
Phone : +91 731 2720143 / 4232900 / 6732700
E-mail: info@jashindia.com

www.jashindia.com